

⚠️ WARNING

This Enclosure will NOT protect against noise, engine exhaust, chemicals, collision, roll-over or other accidents.

⚠️ WARNING

When your UTV is at idle with your Enclosure installed, make sure to open a side door to ensure proper ventilation against carbon monoxide.

⚠️ WARNING

Operating a UTV with this Enclosure will restrict your field of vision.

⚠️ WARNING

Usage of this Enclosure DOES NOT negate the necessity of wearing a helmet.

INSTALLATION

1. Unfold your Enclosure and lay it on the ground with the outside of the roof facing up. Take care not to scratch the windows of your Enclosure.
2. Unzip the doors and remove from the Enclosure. This will greatly aid the fitting of the Enclosure.
3. Pull your Enclosure over the roll cage/frame. Center the front and back sections so that they are level with the roll cage frames.
4. Raise the cowl cover and attach the elasticized clips [A] to the corresponding points in the cowl area. Pull your Enclosure tight against the cowl and close the cowl cover.
5. Secure all interior buckles and fabric sleeves [B] to the roll cage.
6. Reattach the doors to the Enclosure.
7. Find the rip-and-grip attachment points [C] on your Enclosure. Clean the corresponding areas on your UTV with alcohol or other non-abrasive cleaner.
8. Install the enclosed adhesive-backed rip-and-grip strips on to your UTV so that they line up with the rip-and-grip panels on your Enclosure. For best results and to help the adhesive cure, do this in a warm environment, like a heated garage.
9. Attach your Enclosure to the rip-and-grip strips. If possible, don't pull your Enclosure off the strips too soon. **It's best to let the adhesive on the back of the rip-and-grip strips cure for 24 hours before your first use.**

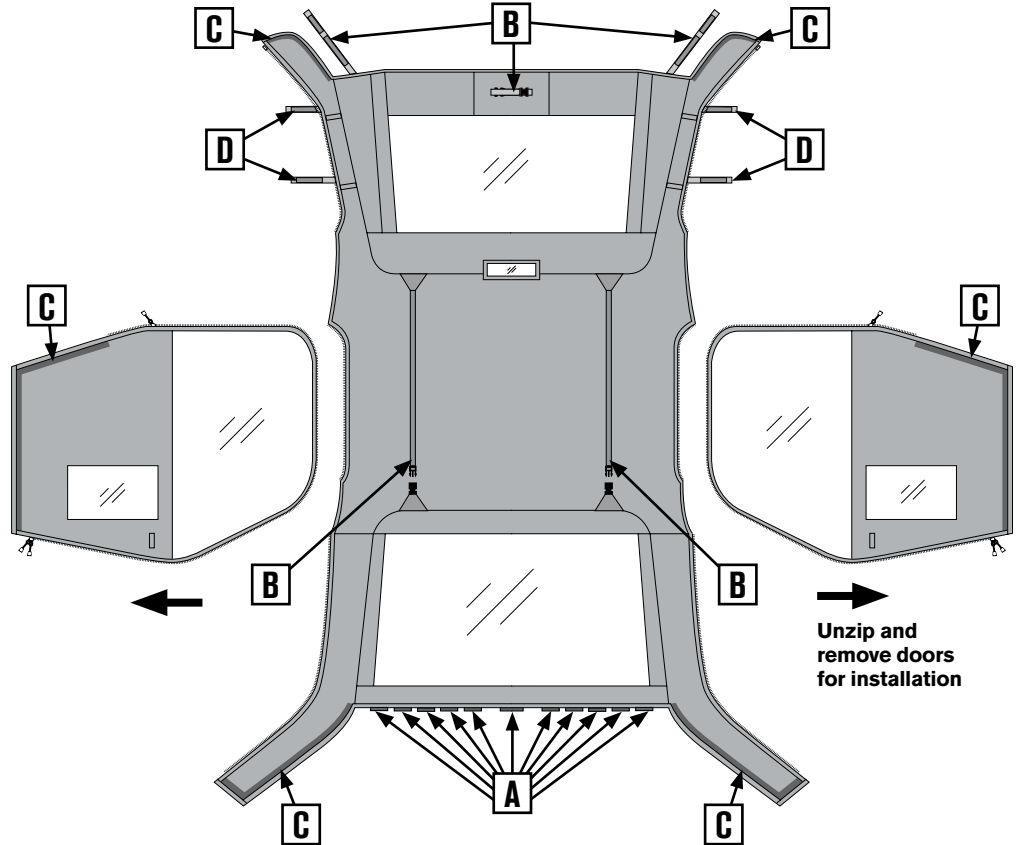

USAGE

The doors of your Enclosure can be rolled sideways out of the way and secured with the attached rip-and-grip straps [D]. The doors also can be unzipped and removed completely.

CLEANING

Clean your Enclosure with a soft brush and warm water. DO NOT USE SOAP as it can damage the protective coatings on the fabric. Air dry.

STORAGE

To avoid mildew be sure that your Enclosure is completely dry before you store it for an extended period in an enclosed area.

WARRANTY

Your Enclosure is factory warranted for workmanship and materials for two years after purchase.



Classic Accessories, Inc.
Kent, WA, USA 98032
www.classicaccessories.com

⚠️ WARNING

This Enclosure will NOT protect against noise, engine exhaust, chemicals, collision, roll-over or other accidents.

⚠️ WARNING

When your UTV is at idle with your Enclosure installed, make sure to open a side door to ensure proper ventilation against carbon monoxide.

⚠️ WARNING

Operating a UTV with this Enclosure will restrict your field of vision.

⚠️ WARNING

Usage of this Enclosure DOES NOT negate the necessity of wearing a helmet.

INSTALLATION

1. Unfold your Enclosure and lay it on the ground with the outside of the roof facing up. Take care not to scratch the windows of your Enclosure.
2. Unzip the doors and remove from the Enclosure. This will greatly aid the fitting of the Enclosure.
3. Pull your Enclosure over the roll cage/frame. Center the front and back sections so that they are level with the roll cage frames.
4. Attach the cutouts in the Enclosure [A] to the corresponding points on the roll cage bars.
5. Reattach the doors to the Enclosure.
6. Find the rip-and-grip attachment points [B] on your Enclosure. Clean the corresponding areas on your UTV with alcohol or other non-abrasive cleaner.
7. Install the enclosed adhesive-backed rip-and-grip strips on to your UTV so that they line up with the rip-and-grip panels on your Enclosure. For best results and to help the adhesive cure, do this in a warm environment, like a heated garage.
8. Attach your Enclosure to the rip-and-grip strips. If possible, don't pull your Enclosure off the strips too soon. **It's best to let the adhesive on the back of the rip-and-grip strips cure for 24 hours before your first use.**

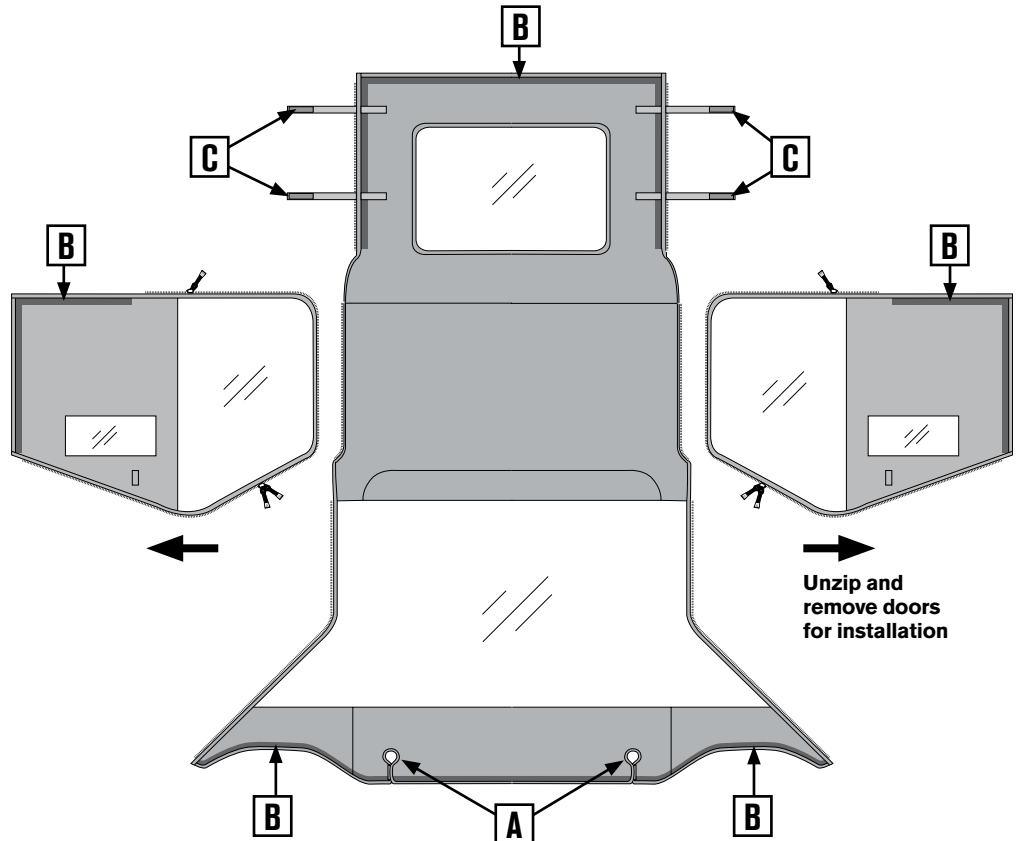

USAGE

The doors of your Enclosure can be rolled sideways out of the way and secured with the attached rip-and-grip straps [C]. The doors also can be unzipped and removed completely.

CLEANING

Clean your Enclosure with a soft brush and warm water. DO NOT USE SOAP as it can damage the protective coatings on the fabric. Air dry.

STORAGE

To avoid mildew be sure that your Enclosure is completely dry before you store it for an extended period in an enclosed area.

WARRANTY

Your Enclosure is factory warranted for workmanship and materials for two years after purchase.



Classic Accessories, Inc.
Kent, WA, USA 98032
www.classicaccessories.com

⚠️ WARNING

This Enclosure will NOT protect against noise, engine exhaust, chemicals, collision, roll-over or other accidents.

⚠️ WARNING

When your UTV is at idle with your Enclosure installed, make sure to open a side door to ensure proper ventilation against carbon monoxide.

⚠️ WARNING

Operating a UTV with this Enclosure will restrict your field of vision.

⚠️ WARNING

Usage of this Enclosure DOES NOT negate the necessity of wearing a helmet.

INSTALLATION

1. Unfold your Enclosure and lay it on the ground with the outside of the roof facing up. Take care not to scratch the windows of your Enclosure.
2. Unzip the doors and remove from the Enclosure. This will greatly aid the fitting of the Enclosure.
3. Pull your Enclosure over the roll cage/frame. Center the front and back sections so that they are level with the roll cage frames.
4. Raise the cowl cover and attach the elasticized clips [A] to the corresponding points in the cowl area. Pull your Enclosure tight against the cowl and close the cowl cover.
5. Secure all interior buckles and fabric sleeves [B] to the roll cage.
6. Reattach the doors to the Enclosure.
7. Find the rip-and-grip attachment points [C] on your Enclosure. Clean the corresponding areas on your UTV with alcohol or other non-abrasive cleaner.
8. Install the enclosed adhesive-backed rip-and-grip strips on to your UTV so that they line up with the rip-and-grip panels on your Enclosure. For best results and to help the adhesive cure, do this in a warm environment, like a heated garage.
9. Attach your Enclosure to the rip-and-grip strips. If possible, don't pull your Enclosure off the strips too soon. **It's best to let the adhesive on the back of the rip-and-grip strips cure for 24 hours before your first use.**

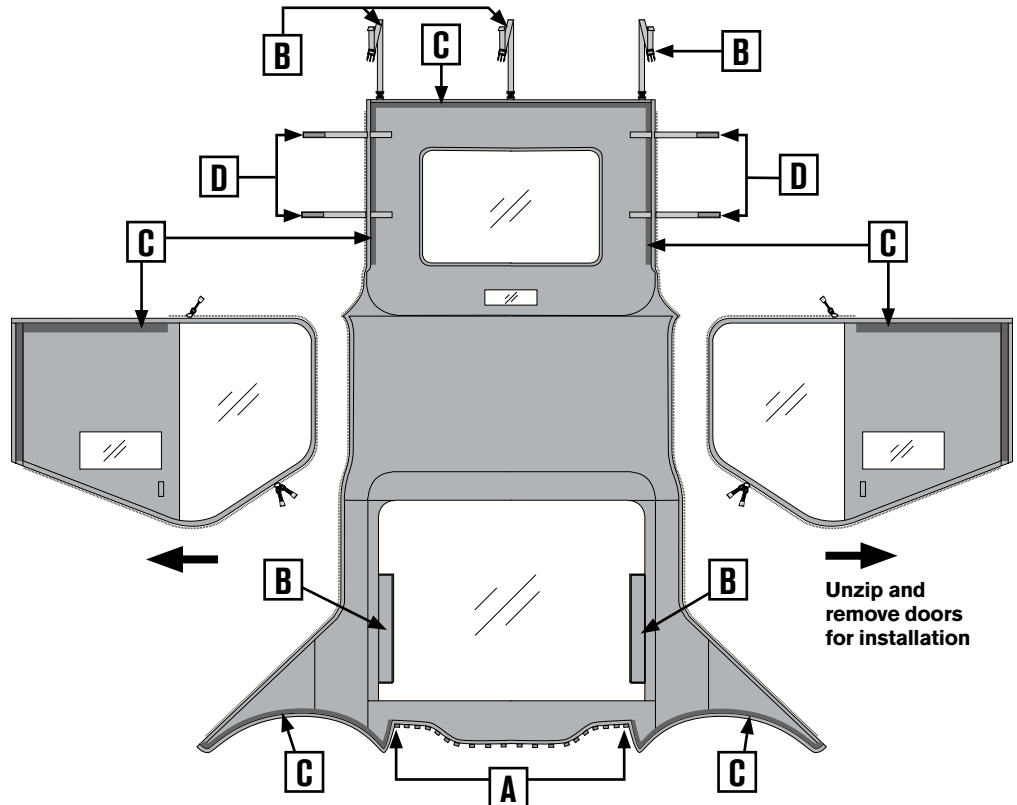

USAGE

The doors of your Enclosure can be rolled sideways out of the way and secured with the attached rip-and-grip straps [D]. The doors also can be unzipped and removed completely.

CLEANING

Clean your Enclosure with a soft brush and warm water. DO NOT USE SOAP as it can damage the protective coatings on the fabric. Air dry.

STORAGE

To avoid mildew be sure that your Enclosure is completely dry before you store it for an extended period in an enclosed area.

WARRANTY

Your Enclosure is factory warranted for workmanship and materials for two years after purchase.



Classic Accessories, Inc.
Kent, WA, USA 98032
www.classicaccessories.com

WARNING

This Enclosure will NOT protect against noise, engine exhaust, chemicals, collision, roll-over or other accidents.

WARNING

When your UTV is at idle with your Enclosure installed, make sure to open a side door to ensure proper ventilation against carbon monoxide.

WARNING

Operating a UTV with this Enclosure will restrict your field of vision.

WARNING

Usage of this Enclosure DOES NOT negate the necessity of wearing a helmet.

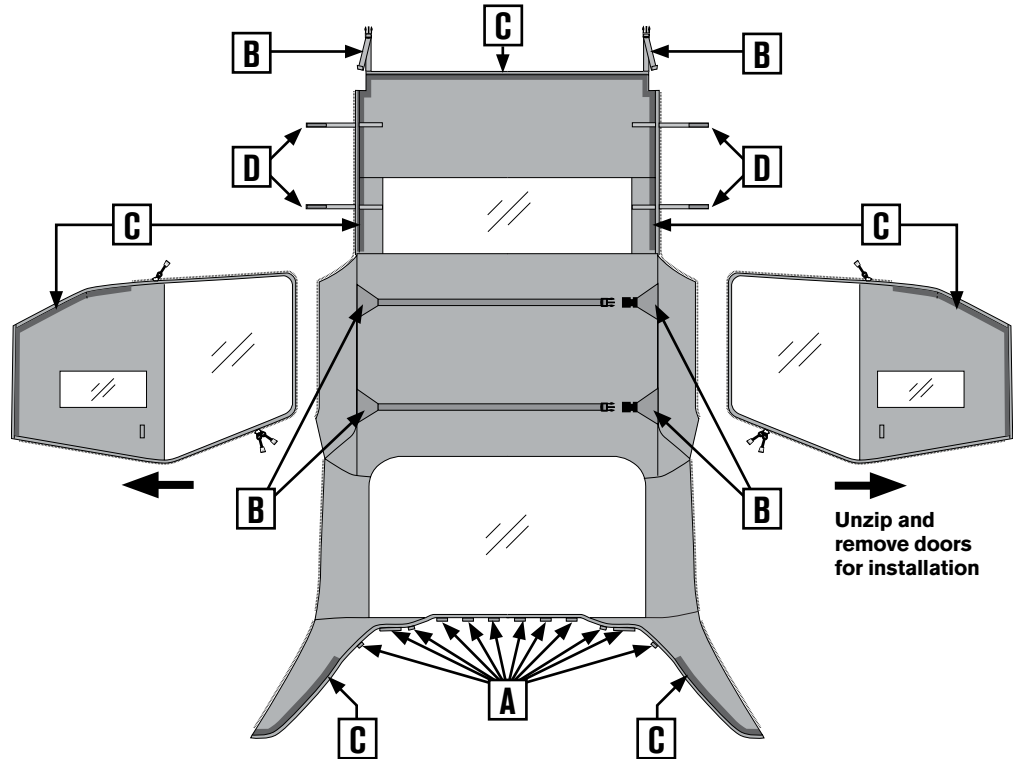

INSTALLATION

1. Unfold your Enclosure and lay it on the ground with the outside of the roof facing up. Take care not to scratch the windows.
2. Unzip the doors and remove from the Enclosure. This will greatly aid the fitting of the Enclosure.
3. Pull your Enclosure over the roll cage/frame. Center the front and back sections so that they are level with the roll cage frames.
4. Raise the cowl cover and attach the elasticized clips [A] to the corresponding points in the cowl area. Pull your Enclosure tight against the cowl and close the cowl cover.
5. Secure all interior buckles [B] to the roll cage.
6. Reattach the doors to the Enclosure.
7. Find the rip-and-grip attachment points [C] on your Enclosure. Clean the corresponding areas on your UTV with alcohol or other non-abrasive cleaner.
8. Install the enclosed adhesive-backed rip-and-grip strips on to your UTV so that they line up with the rip-and-grip panels on your Enclosure. For best results and to help the adhesive cure, do this in a warm environment, like a heated garage.
9. Attach your Enclosure to the rip-and-grip strips. If possible, don't pull your Enclosure off the strips too soon. **It's best to let the adhesive on the back of the rip-and-grip strips cure for 24 hours before your first use.**

USAGE

The doors of your Enclosure can be rolled sideways out of the way and secured with the attached rip-and-grip straps [D]. The doors also can be unzipped and removed completely.

CLEANING

Clean your Enclosure with a soft brush and warm water. **DO NOT USE SOAP** as it can damage the protective coatings on the fabric. Air dry.

STORAGE

To avoid mildew be sure that your Enclosure is completely dry before you store it for an extended period in an enclosed area.

WARRANTY

Your Enclosure is factory warranted for workmanship and materials for two years after purchase.



**CLASSIC
ACCESSORIES**

WE COVER YOUR GEAR™

Classic Accessories, Inc.
Kent, WA, USA 98032
www.classicaccessories.com

UTV ENCLOSURE

For Yamaha UTVs



WARNING

This Enclosure will NOT protect against noise, engine exhaust, chemicals, collision, roll-over or other accidents.

WARNING

When your UTV is at idle with your Enclosure installed, make sure to open a side door to ensure proper ventilation against carbon monoxide.

WARNING

Operating a UTV with this Enclosure will restrict your field of vision.

WARNING

Usage of this Enclosure DOES NOT negate the necessity of wearing a helmet.

NOTE

This product is designed for use with 1/2 safety doors that are now standard safety equipment on Yamaha UTVs. It can also be installed on older Yamahas without the doors but we strongly suggest that you contact your Yamaha dealer for further information about this safety door.

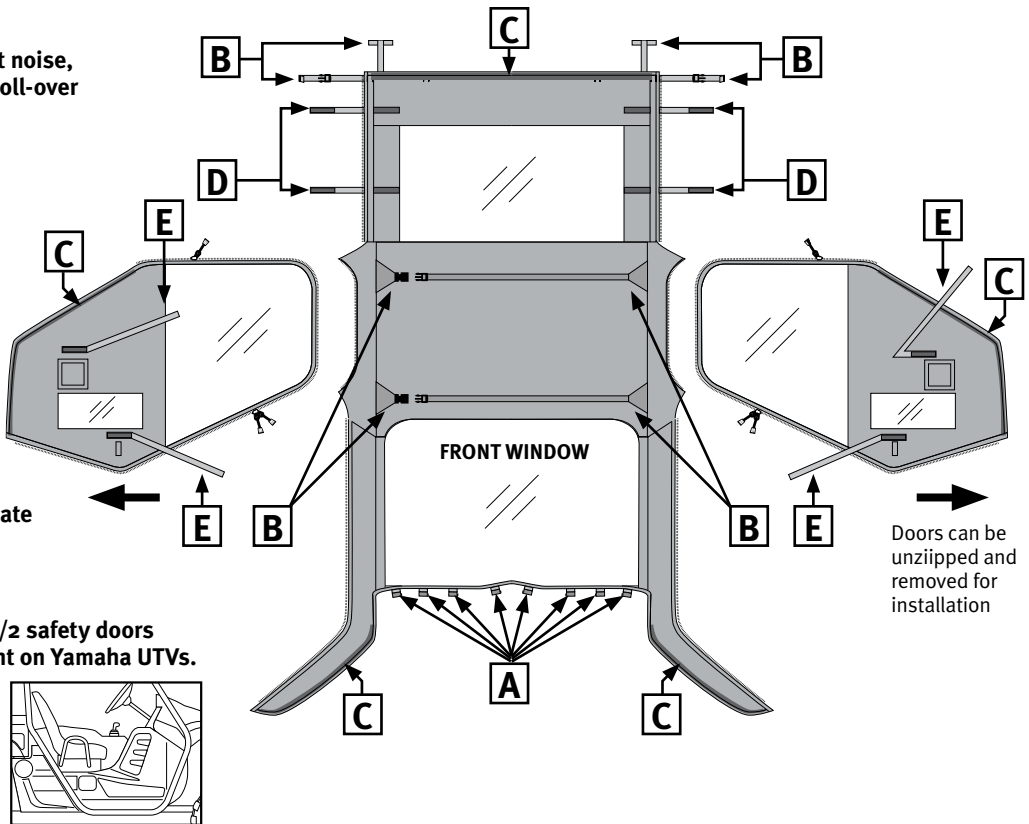

INSTALLATION NOTE

Parts of your enclosure have extra rip-and-grip tape attachments. It's best to let the adhesive on the back of the tape cure in a warm environment like a heated garage for 24 hours before your first use. We suggest that you attach these first.

1. Unfold your Enclosure and lay it on the ground or the bed of the UTV; with the outside of the roof facing up. Take care not to scratch the windows. Unzip the doors along the sides.
2. Loosely drape your Enclosure over your UTV roll cage frame with the front window [A] to the front of your ATV. Center the front and back sections so that they are level with the roll cage frames.
3. Find the rip-and-grip attachment points [C] on your Enclosure. Clean the corresponding areas on your UTV with alcohol or other non-abrasive cleaner. Apply the strips on your UTV to match as follows:

Locate the provided twelve small adhesive-backed rip-and-grip strips. Apply to the front and outside of the front roll bars, six per side, spaced evenly (Fig. 01). Press down firmly.



For best performance, apply the rip-and-grip to the bottom of your enclosure doors, the fenders and the bottom of the rear panel with adhesive backed rip-and-grip tape cut from the provided roll.

Note that the door bottoms can be secured to the frame around the door or, if you have the the 1/2 safety door, the bottom of the safety door (Fig 02). See the note above regarding safety doors.

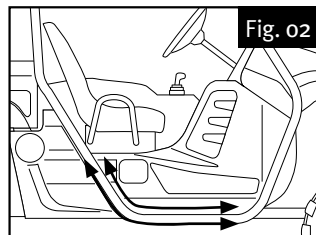

There are also four rip-and-grip strips for the door straps that can be attached after installation (see USAGE).

4. Raise the cowl cover and attach the elasticized clips [A] to the corresponding points in the cowl area. Close the cowl cover.
5. Starting at the front window, secure all interior buckles [B] to the roll cage, working the tension over the top to the back. Tighten.
6. Re-attach the doors if needed.
7. Attach your Enclosure to the rip-and-grip strips.

USAGE

The doors of your Enclosure can be rolled toward the back and secured with the attached rip-and-grip straps [D] or the doors can roll down to attach with straps [E] to the safety door. When rolled down, the straps on the outside of your Enclosure door [E] can attach to four provided adhesive backed rip-and-grip strips that you apply to the inside of the UTV safety door. The doors also can be unzipped and completely removed.

CLEANING

Clean your Enclosure with a soft brush and warm water. DO NOT USE SOAP as it can damage the protective coatings on the fabric. Air dry.

STORAGE

To avoid mildew be sure that your Enclosure is completely dry before you store it for an extended period in an enclosed area.

WARRANTY

Your Enclosure is factory warranted for workmanship and materials for two years after purchase.



Classic Accessories, Inc.
Kent, WA, USA 98032
www.classicaccessories.com

©2008

78003, 78007 08c0A55_10128

UTV ENCLOSURE FOR KAWASAKI® 610 UTVS



⚠ WARNING

This Enclosure will NOT protect against noise, engine exhaust, chemicals, collision, roll-over or other accidents.

⚠ WARNING

When your UTV is at idle with your Enclosure installed, make sure to open a side door to ensure proper ventilation against carbon monoxide.

⚠ WARNING

Operating a UTV with this Enclosure will restrict your field of vision.

⚠ WARNING

Usage of this Enclosure DOES NOT negate the necessity of wearing a helmet.

INSTALLATION

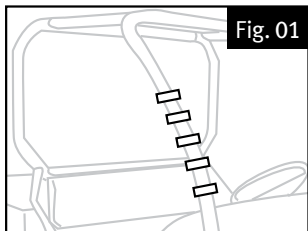

Apply the adhesive-backed Rip-and-Grip strips to front, outside of the front roll bars, 5 per side, spaced evenly (Fig. 01). Press firmly and allow 24 hours for adhesive strips to cure.

Unzip the doors and remove from the enclosure.

Loosely drape the enclosure over UTV with the Front label facing toward the front of the UTV. Be careful the metal clips do not strike the UTV. Pull enclosure toward the front to provide enough slack to attach the front corner attachment clips. Attach the clips (A) at both front corners by hooking the short arm on the back of the front roll cage bar terminal, and holding firmly, rotate the clip toward the front. Apply light pressure and click into place.

Starting at the clips, pull cover up and attach to Rip-and-Grip strips on front roll cage. Make sure cover is centered on the roll cage.

Continue pulling the enclosure over the top and down the back of your UTV.

Connect the back Vertical straps and Horizontal straps (B). Inside the roof, attach the inside tension straps by wrapping the straps around the roll cage bars from front to back. Pull tight.

Pull down at the bottom of the doors and fenders to determine where the doors and fender adhesive Rip-and-Grip will go. It is not necessary to use all the Rip-and-Grip strips. You may want to use just 6" approx. at the bottom of the front fenders (C).

Re-attach doors.

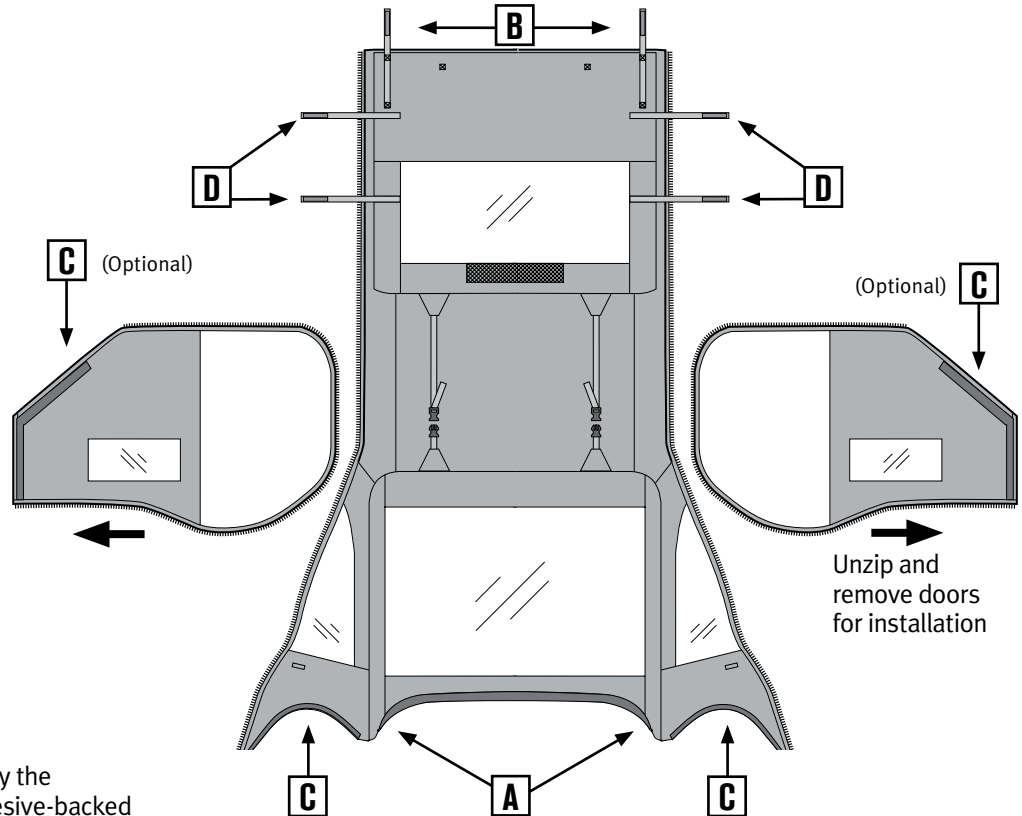

When Rolling doors up: Loop lower door wrap around seat arm, which will pull the rolled up door out of the way of the dump mechanism.

USAGE

The doors of your Enclosure can be rolled sideways out of the way and secured with the attached Rip-and-Grip straps (D). The doors also can be unzipped and removed completely.

CLEANING

Clean your Enclosure with a soft brush and warm water.

DO NOT USE SOAP as it can damage the protective coatings on the fabric. Air dry.

STORAGE

To avoid mildew be sure that your Enclosure is completely dry before you store it for an extended period in an enclosed area.

WARRANTY

Your Enclosure is factory warranted for workmanship and materials for two years after purchase.



Classic Accessories, Inc.
Kent, WA, USA 98032
www.classicaccessories.com